

NOBLE™

FIRE TUBE COMBI

SMART CONTROL™

ENHANCED OPERATING SYSTEM

THREE SIZES:

110,000, 150,000 AND 199,999 BTU/HR

INDUSTRY-LEADING DHW DELIVERY UP TO 4.8 GPM

TRUE INSTANTANEOUS RESPONSE

EASY INSTALLATION AND SERVICEABILITY

USER-FRIENDLY INTERFACE



Most Efficient
2017

www.energystar.gov



95% **AFUE EFFICIENCY**
AHRI CERTIFIED™
www.ahridirectory.org



Lochinvar®
HIGH EFFICIENCY BOILERS & WATER HEATERS

DESIGNED ★ ENGINEERED ★ ASSEMBLED
USA

NOBLE™ FIRE TUBE COMBI

A Game-Changer In Combi Water Heating

Lochinvar has long been the innovation leader in commercial boilers—and now it's bringing that engineering excellence to residential combi boilers. Lochinvar's legendary reliability and performance are now available for apartments and homes, where the combi boiler's next-generation fire tube design can provide hot water supply and space heating faster and more efficiently than ever before.

The NOBLE™ combi boiler provides a space-saving choice for builders and specifiers, lowering installation costs by reducing the mechanical equipment needed to provide rapid, reliable hot water supply and efficient space heating. It also gives plumbing contractors a money-saving alternative for single-family housing with 1 or 2 bathrooms.



Advanced Electronic Control

The backlit, user-friendly LCD display provides diagnostic information and system status in *real words, not codes*. The Set-Up Wizard display makes it simple to set system parameters in just minutes, including:

Space Heat Set Point (Coldest Day) Domestic Hot Water Set Point

Maximum Space Heat Set Point Space Heat Rate Limiting

Auto Reset High Limit Outdoor Temperature/Warm Weather Shutdown

What Makes NOBLE The Best Combi Boiler?

DELIVERS MORE HOT WATER

It's sized large enough to quickly meet domestic hot water (DHW) load. Provides DHW from 2.6 (NKC110) to 4.8 gpm (NKC199) at a 77°F temperature rise.

FASTER DHW RESPONSE TIME

With many combi boilers when you turn on a hot water faucet, you initially get hot water and then a brief burst of cold water before the hot water resumes. Thanks to its patent-pending control technology, this combi boiler eliminates this cold water "sandwich."

QUIET OPERATION

Operates so silently that you often have to look at the user-friendly interface to see if it's running.

EASIER TO INSTALL AND PROGRAM

With our Set-Up Wizard, you can program the boiler in less than two minutes. The user-friendly interface uses real words—*not confusing codes*—to guide the installer in setting up vital system parameters.

BETTER TECHNICAL SUPPORT AND TRAINING

Answers are accessible whether online or on-campus. LochinvarU.com is always on, 24/7 for technical support. And Lochinvar University is the industry's best-equipped training center.

10:1 TURNDOWN RATIO

Operates as low as 10% of the maximum firing rate, preventing on/off short cycling at the lowest DHW demands or small heating demands.

AIR HANDLER INTERLOCK

Prevents cool air circulation in Hydro-Air installations when the appliance is making DHW.

CONSUMER FINANCING AVAILABLE

Check with your local Sales Representative for additional information.

Raising the Bar in Combi Boiler Design

Removing the front panel provides convenient access to the combustion system, control panel and key components. This simple-to-install-and-service combi boiler is making an impact on the industry.

The unique fire tube heat exchanger design is what enables NOBLE to produce the results users deserve and have come to expect from Lochinvar.

1 ADAPTER-FREE FLUE CONNECTION

Multi-material connector allows either PVC, CPVC, polypropylene or stainless steel connection directly to the appliance without adapters. NOBLE also has a built-in combustion analyzer port.

2 DIRECT VENTING UP TO 100 FEET

Offers five venting options for tremendous installation flexibility. It permits direct-vent air intake and exhaust runs up to 100 equivalent feet using either PVC, CPVC, polypropylene or AL29-4C stainless steel vent pipe.

3 ADVANCED NEGATIVE REGULATION TECHNOLOGY

Safely and reliably operates with supply gas pressure as low as 4 inches water column. Its negative regulation (neg/reg) technology eliminates mechanical dampers as it automatically adjusts fan speed to ensure the correct volume and mix of fuel and air throughout the firing range.

4 INNOVATIVE FIRE-TUBE HEAT EXCHANGER

The fire tube design can produce a higher heat transfer coefficient than traditional fire tubes.

5 BRAZED PLATE HEAT EXCHANGER

Stainless Steel Heat Exchanger that quickly transfers heat from the boiler system to the domestic water satisfying DHW load.

6 WATER CONNECTIONS FOR EASY INSTALLATION

NPT water connections make installation easy, especially with our optional isolation valves.



NOBLE Dimensions and Specifications

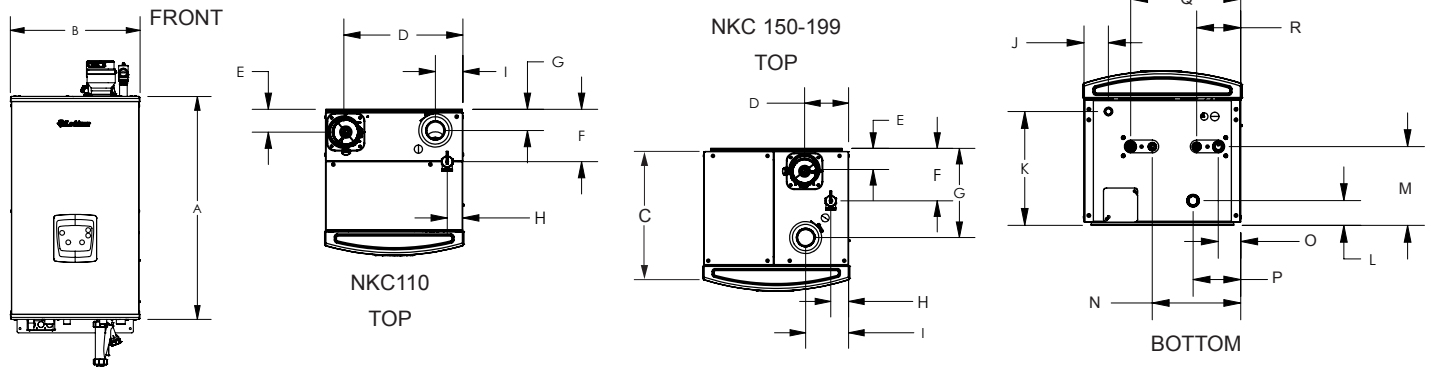

NOBLE COMBI BOILER						DIMENSIONS AND SPECIFICATIONS						
Model Number	Input (MBH) Max.	Input (MBH) Min.	AFUE%	Heating Capacity MBH	Net AHRI Rating MBH	A	B	C	D	E	F	G
NKC110N	110	11	95.0	102	89	32-1/2"	17-1/4"	18"	14-3/4"	2-3/4"	6-1/2"	2-3/4"
NKC150N	150	15	95.0	139	121	32-1/2"	18-3/4"	18"	6-3/4"	2-3/4"	6-3/4"	11-3/4"
NKC199N	199	19.9	95.0	185	161	32-1/2"	18-3/4"	18"	5-1/2"	2-3/4"	6-3/4"	11-1/2"

DIMENSIONS AND SPECIFICATIONS															
H	I	J	K	L	M	N	O	P	Q	R	Gas Conn.	Water Conn.	Air Inlet	Vent Size	Shipping Weight
2"	3-1/2"	8-3/4"	13-1/2"	2-3/4"	9"	10-1/2"	5"	14-1/2"	12-3/4"	5"	1/2"	1"	3"	3"	139
2-1/2"	6-1/4"	2-3/4"	13-1/2"	3"	9"	11-1/2"	5"	6-1/4"	13-3/4"	6"	1/2"	1"	3"	3"	142
2-1/4"	5-1/2"	2-3/4"	13-1/2"	2-3/4"	9-1/2"	10-1/2"	2-3/4"	5-1/2"	13"	5-1/4"	1/2"	1"	3"	3"	159

Notes: Indoor installation only. All information subject to change. Change "N" to "L" for LP gas models. *The Net AHRI Water Ratings shown are based on a piping and pickup allowance of 1.15.

Model	DHW Delivery (GPM)*
NKC110N	2.6
NKC150N	3.6
NKC199N	4.8

* 77°F Temperature Rise

SMART CONTROL™ FEATURES

- ▶ **SMART CONTROL Digital Operating Control**
LCD Display with words not codes
- ▶ **Outdoor Reset Control with Outdoor Air Sensor**
- ▶ **Programmable System Efficiency Optimizers**
DHW Response Time
DHW Pre Heat
Outdoor Air Reset Curve
- ▶ **Two Pump Control**
System Pump
Boiler Pump
- ▶ **High-Voltage Junction Box**
120 VAC / 60 Hertz / 1 Phase Power Supply
- ▶ **Low Voltage Terminal Strip**

- Air Handler Interlock
- Flow Switch Contacts
- Low-Water Cutoff Connection
- System Sensor Contacts
- Outdoor Air Sensor Contacts
- Cascade Contacts

- ▶ **Time Clock for Data Logging**
Last 10 Lockouts
- ▶ **Low-Water Flow Safety Control & Indication**
- ▶ **Password Security**
- ▶ **Built-in Cascading Sequencer for up to 8 units**

STANDARD FEATURES

- ▶ **ENERGY STAR Most Efficient Recognition**
- ▶ **95% DOE AFUE Efficiency**
- ▶ **Modulating Burner with 10:1 Turndown**
Direct-Spark Ignition
Low-NOx Operation
- ▶ **ASME Stainless Steel Heat Exchanger**
50 psi Working Pressure w/ASME Relief Valve
- ▶ **Vertical & Horizontal Direct-Vent**
PVC, CPVC, Polypropylene or SS Venting up to 100 feet
- ▶ **Condensate Trap**
- ▶ **Other Features**
Automatic Reset High Limit

- Adjustable High Limit w/Manual Reset
- Built-in Circulating Pump
- Wall-Mount Bracket
- Zero Clearances to Combustible Materials
- 10-Year Warranty
(See Warranty for Details)
- 5-Year Parts Warranty

OPTIONAL EQUIPMENT

- Low-Water Cutoff w/Manual Reset & Test
- Concentric Vent Kit
- Condensate Neutralization Kit
- Sidewall Vent Termination
- Floor Stand
- Wireless Outdoor Sensor
- Nat to LP Gas Conversion Kit
- Isolation/Flush Valves

FIRING CODES

- ▶ M9 Standard Construction/California Code

*Lochinvar should be consulted before selecting a boiler for installations having unusual piping and pickup requirements, such as intermittent system operation, extensive piping systems, etc.
*The ratings have been determined under the provisions governing forced draft burners.



Lochinvar, LLC
300 Maddox Simpson Parkway
Lebanon, Tennessee 37090
P: 615.889.8900 / F: 615.547.1000
Lochinvar.com

